

**SCHEMA TECNICA**

Famiglia: **COCKER**  
Design: **Caimi Lab**

Phone-booth a parete.

Descrizione:

Phone-booth composto da: una struttura, realizzata in tondino di acciaio  $\varnothing$  11 mm verniciato con polveri epossidiche, dotata di fissaggi a parete; un'imbottitura interna in poliester e un rivestimento esterno in tessuto di poliester e Trevira CS<sup>®</sup>, completamente sfoderabile grazie ad una cerniera in metallo verniciato.

Descrizione pianetto opzionale:

Piano inclinato, realizzato in lamiera di acciaio spessore 2 mm verniciata con polveri epossidiche, con bordo frontale di contenimento ripiegato, dotato nella parte posteriore di fori per il fissaggio a parete.

Dimensioni:

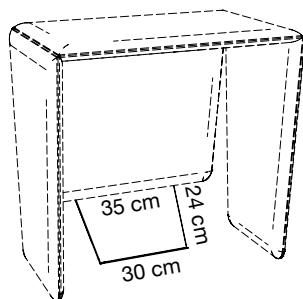
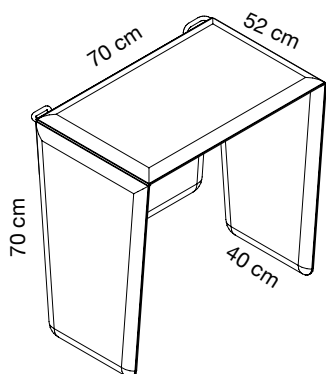

Colori disponibili:

4027



Rosso

8004



Grigio argento

7013



Verde mela

300

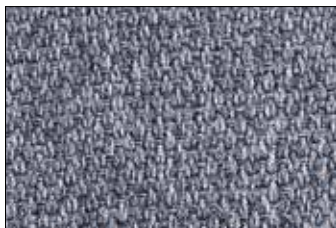

Fiber 3 Melange

305



Fiber 3 Melange

308



Fiber 3 Melange

309



Fiber 3 Melange

311

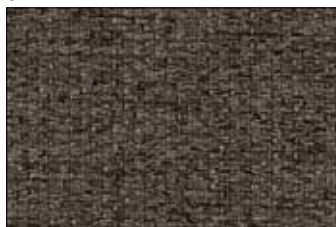

Fiber 3 Melange

312



Fiber 3 Melange



Caimi Brevetti S.p.A. si riserva, a proprio insindacabile giudizio, la facoltà di modificare senza preavviso i materiali, le caratteristiche tecniche ed estetiche, nonché le dimensioni degli elementi illustrati nella presente scheda tecnica le cui immagini e colori sono puramente indicativi.