

SPECIFICATION

Range: **SET**

Design: **Caimi Lab**

Codes: **1SECB5-IN / 1SECB5-I / 1SECB6-IN / 1SECB6-I** (stanchions)

Dimensions: base \varnothing 30 cm
stanchion \varnothing 2,5 cm – H 91 cm o H 46 cm

Description: stanchions composed of a circular base (\varnothing 30 cm), in black embossed epoxy powder-coated steel or covered with concentric satin-finished stainless steel and a satin-finished stainless steel tube (\varnothing 2.5 cm, height 91 cm or 46 cm), which can be screwed into the lower part of the base by means of an M8 screw and has a side hole in the upper part for the attachment of accessories only or the attachment element for cords and accessories, also made of satin-finished stainless steel. The multiple element allows the connection of 4 cords and multifunctional accessories. The connection between stanchions and accessories is achieved thanks to an innovative quick coupling system with snap pin.

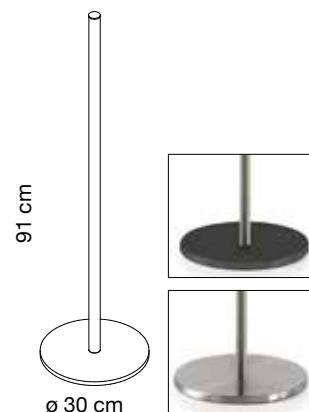

1SECB5-IN (black base)
1SECB5-I (stainless steel base)

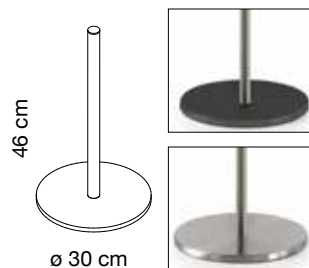

1SECB6-IN (black base)
1SECB6-I (stainless steel base)



Codes: **1SEF3-NB** (large shaped display unit)
1SEFG7-NB (large shaped display stand + cord connection element)

Dimensions: height 26 cm – lenght 22 cm – depth 3,5 cm – edge height front 4 cm (arge shaped display unit)

Description: large shaped display unit made of black embossed epoxy powder-coated steel. They can be hooked directly to the stanchions, or they can be attached to the 4-way satin-finish stainless steel connecting element for cords.

In both cases the coupling is achieved by means of an innovative quick coupling system with snap pin.



Codes: **1SEF2-NB** (brochure holder)
1SEFG8-NB (brochure holder + cord connection element)

Dimensions: height 22 cm – lenght 11,4 cm – edge height front 3 cm (brochure holder)

Description: brochure holder made of black embossed epoxy powder-coated steel. They can be hooked directly to the stanchions, or they can be attached to the 4-way satin-finish stainless steel connecting element for cords.

In both cases the coupling is achieved by means of an innovative quick coupling system with snap pin.



Codes: **1SEF4-NB** (shaped display unit - lectern)
1SEFG9-NB (shaped display unit - lectern + cord connection element)

Dimensions: height 11 cm – lenght 12 cm – edge height front 1,2 cm (display unit - lectern)

Description: display unit - lectern made of black embossed epoxy powder-coated steel. They can be hooked directly to the stanchions, or they can be attached to the 4-way satin-finish stainless steel connecting element for cords.

In both cases the coupling is achieved by means of an innovative quick coupling system with snap pin.

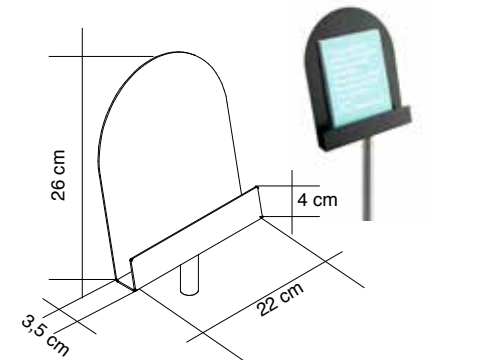

1SEF3-NB

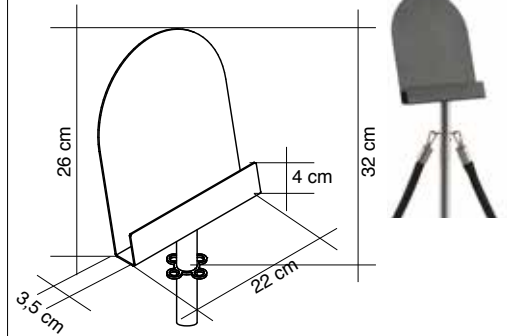

1SEFG7-NB

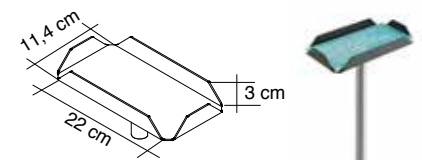

1SEF2-NB

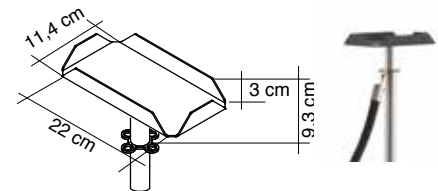

1SEFG8-NB

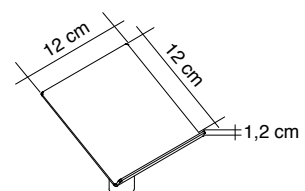

1SEF4-NB

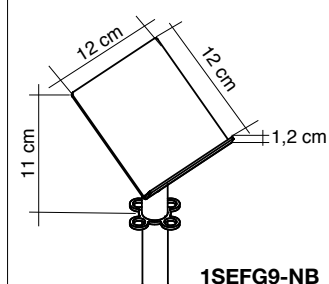

1SEFG9-NB